

New High Speed Steels

“**YXR Series**”

with high toughness and strength for
forming dies and tools



Required properties (1)

Hot forging die & punch

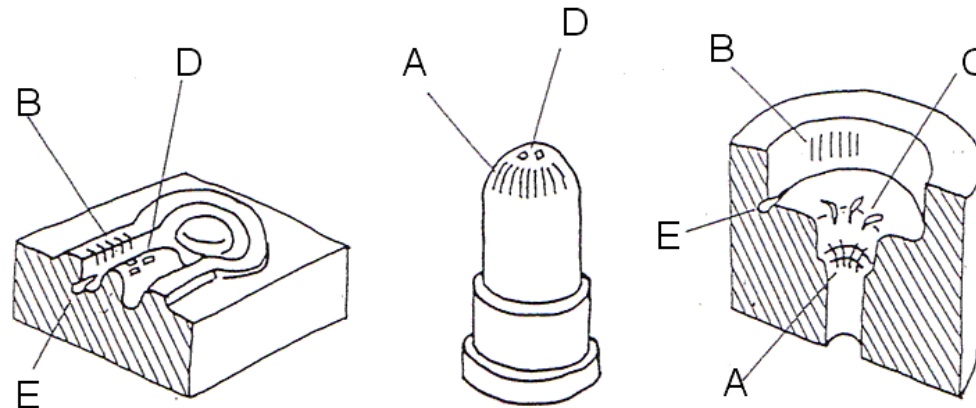

	Damage	Material	Heat treatment	Design, Utility
A	Wear (with heat influence)	Tensile strength at elevated temperature	Nitriding Austenitizing temperature	Die cooling Lubricant
B	Wear	Toughness Carbides (wear resistance)	Surface treatment Hardness	Lubricant Hard material insert
C	Heat check	Tensile strength at elevated temperature Toughness	Quenching speed Hardness Nitrided case depth	Lubricant Die cooling
D	Nitrided case exfoliation	Nitriding properties Tensile strength at elevated temperature	Nitriding condition	Lubricant Die cooling
E	Erosion			Lubricant Gas path
F	Fatal break	Toughness	Quenching speed Hardness Austenitizing temperature Nitriding condition	Pre-heating Surface finish Shrinking Die partition

Hitachi Metals America, Ltd.

Required properties (2)

Cold forging die & punch

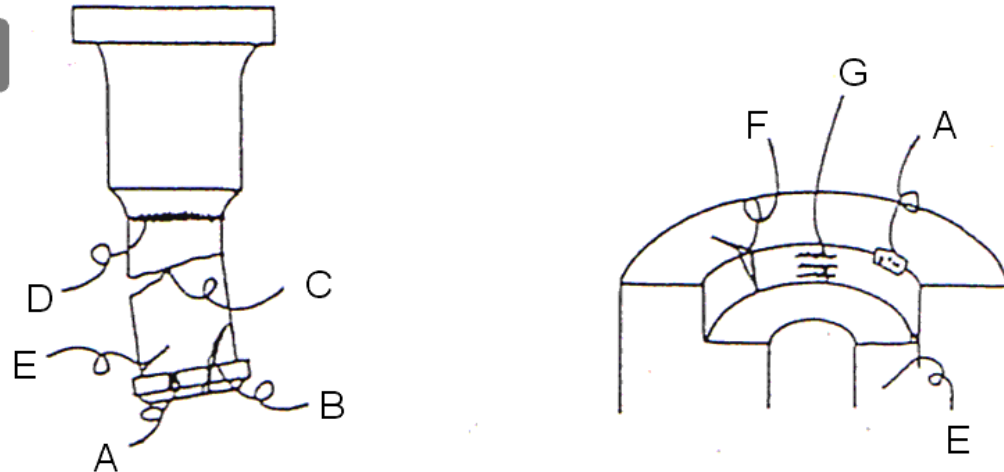

Damage	Cause	Material
A	Excessive impact (Foreign elements, miss-fitting of punch)	Toughness Compressive strength
B	Tensile stress (Friction, punch distortion)	Tensile strength Low friction Compressive strength
C	Bending stress (Center shifting, bending)	Bending strength Compressive strength
D	Cyclic stress	Fatigue strength
E	Compressive shearing stress (Forming pressure)	Compressive strength
F	Tensile stress (Forming pressure)	Tensile strength
G	Tensile stress (Friction)	Scuffing resistance Tensile strength

YXR Series

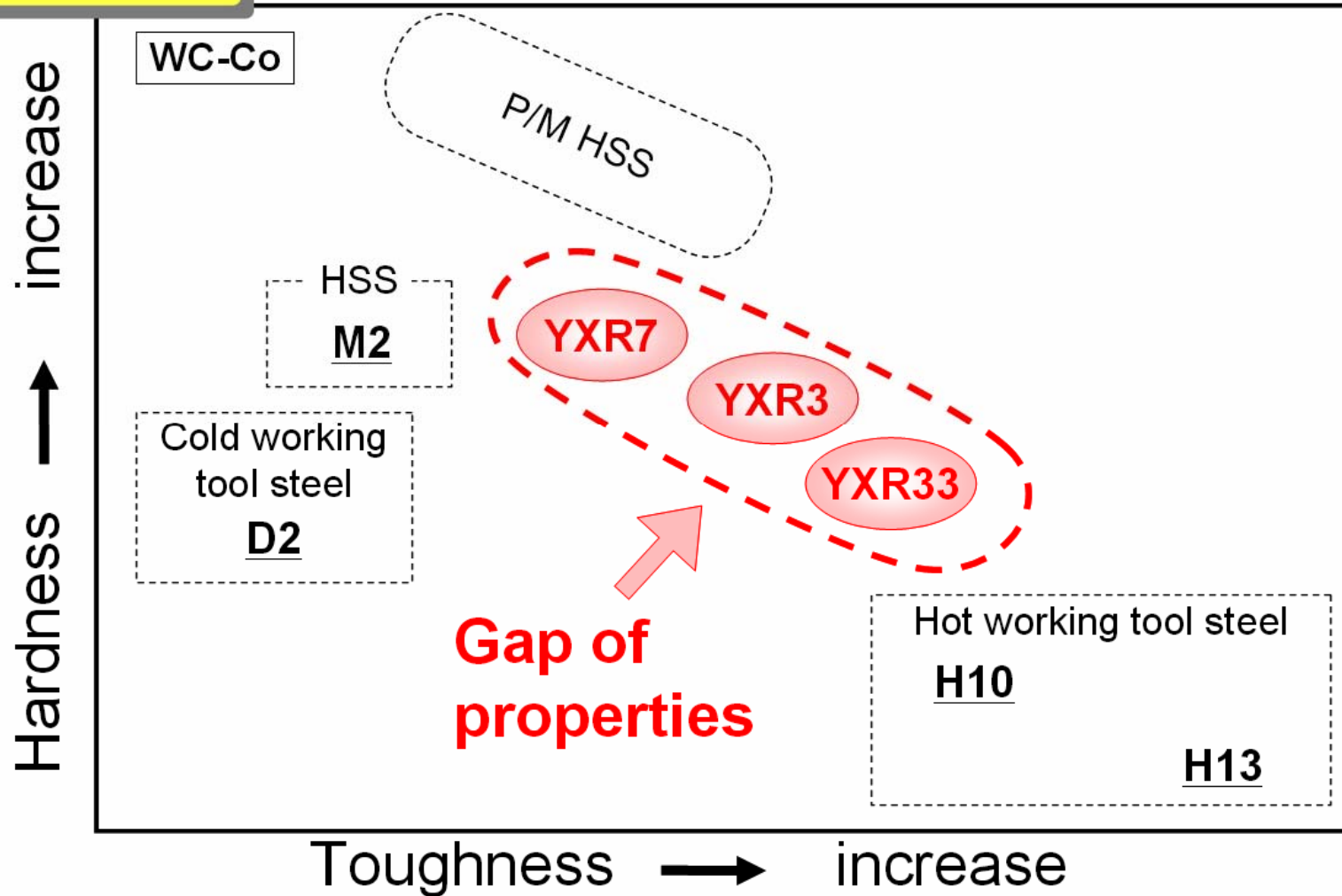

Toughness

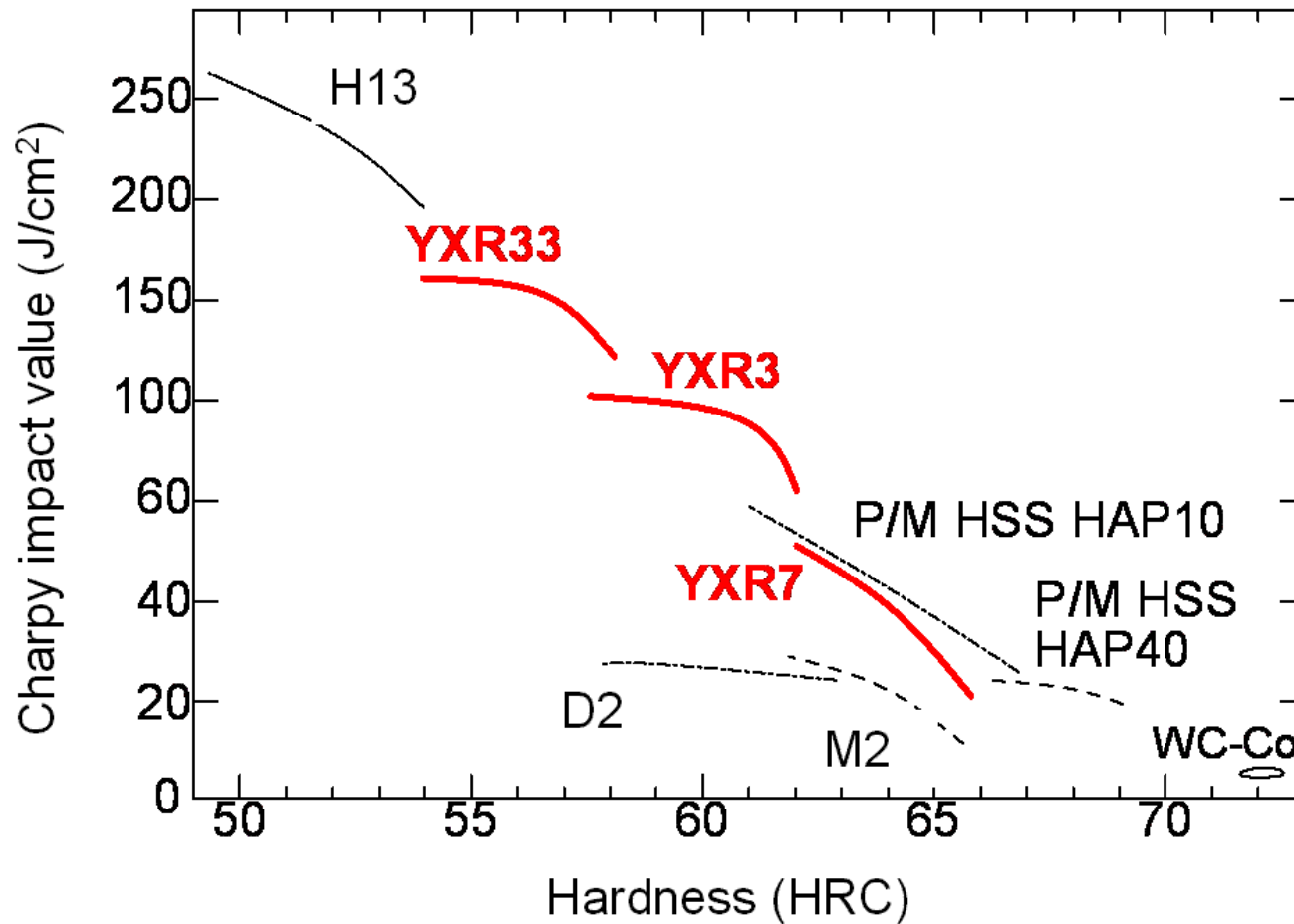

Hitachi Metals America, Ltd.

Bending strength

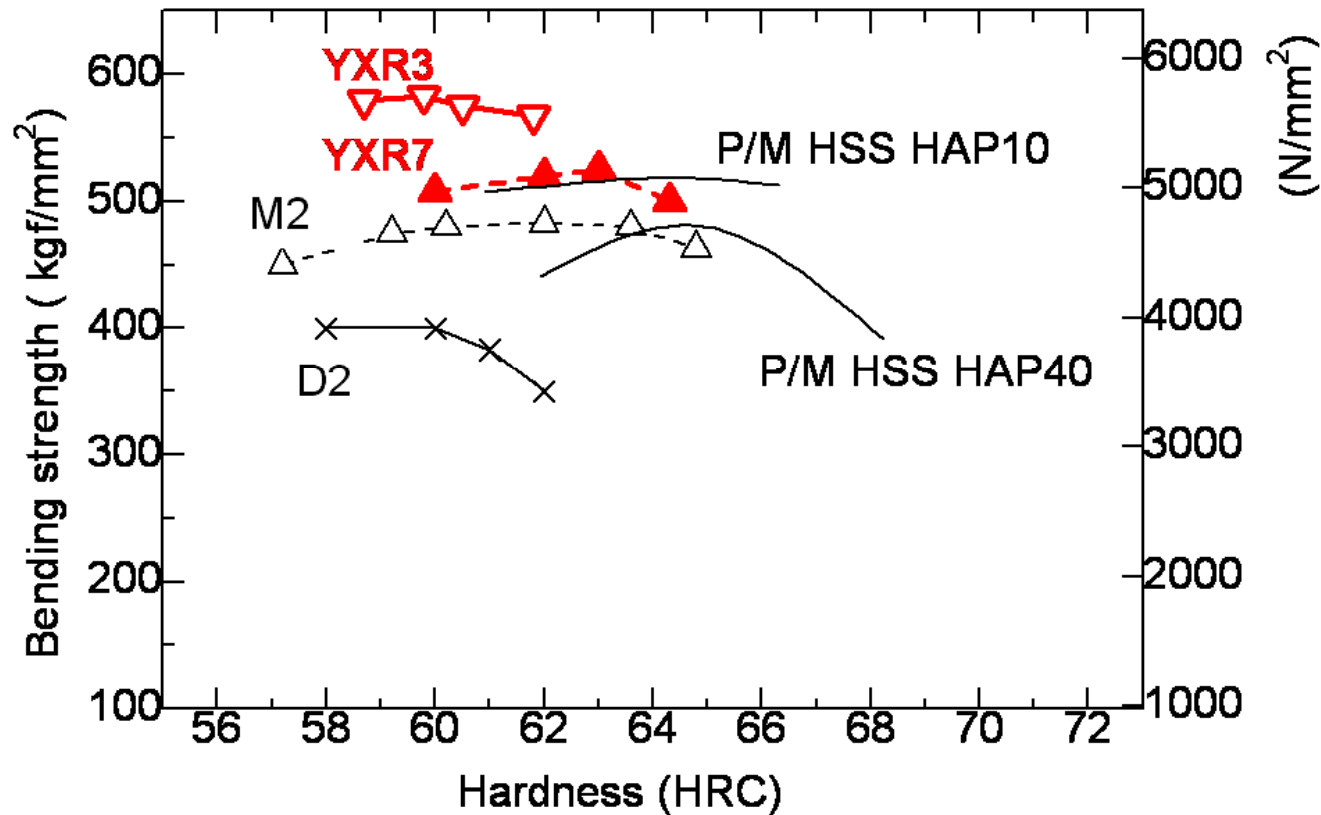

Hitachi Metals America, Ltd.

Fatigue strength

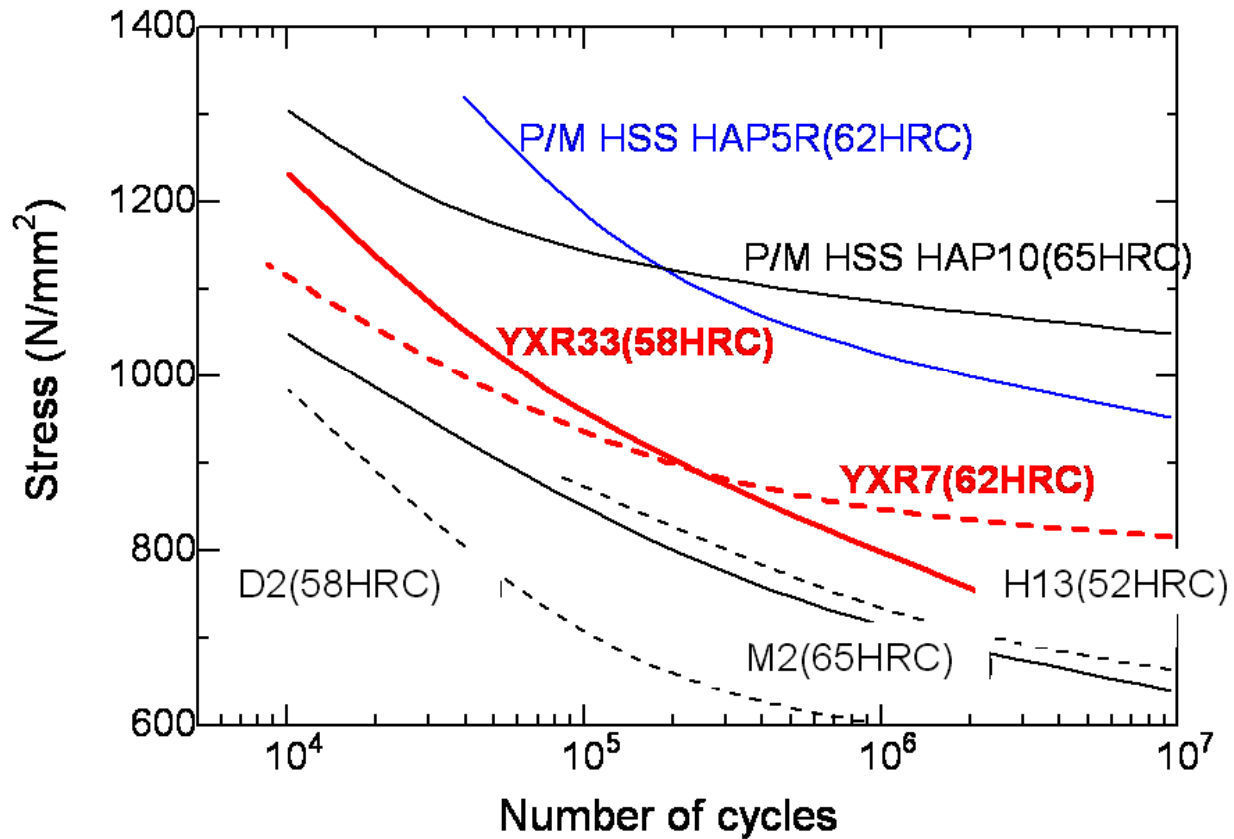

Hitachi Metals America, Ltd.



Heat treatment

	Usual hardness	Quenching	Tempering
YXR7	62-65HRC	1140°C Oil	550-580°C Air
YXR3	58-61HRC	1140°C Oil	550-580°C Air
YXR33	54-58HRC	1080-1140°C Oil	550-600°C Air
M2	58-64HRC	1160-1220°C Oil	550-580°C Air
D2	57-63HRC	1000-1050°C Air	150-200°C Air 510-530°C Air
H13	46-53HRC	1000-1050°C Air	550-680°C Air



Records

Grade	Tool	Work material	Current tool material	Tool life of YXR	
YXR7	Cold forming die	S45C	M2 63HRC Cracking	63HRC Wear	Times 6
	Threading die	SCM440	D2 62HRC Cracking	65HRC Wear	5
	Warm forming punch	S53C	SKD8 58HRC Plastic flow	62HRC Plastic flow	3.5
YXR3	Knockout sleeve	Steel	M2 61HRC Breaking	61HRC Wear	5
	Cold forming punch	Steel	D2 58HRC Chipping	61HRC Wear	2.5
YXR33	Warm forging punch	SUJ2	H13 48HRC Plastic flow	58HRC Plastic flow	7
	Crusher cutter	SHP	M2 61HRC Breaking	58HRC Breaking	20

Hitachi Metals America, Ltd.

Application (1)



x 4



YXR33 (57HRC)

**Good wear resistance
without cracking**

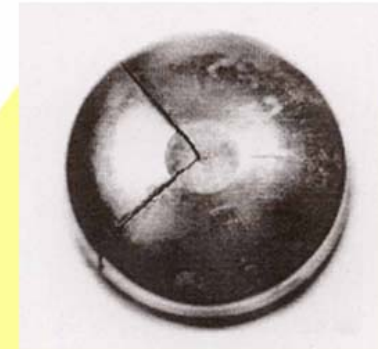

M2 (60HRC)

Cracked

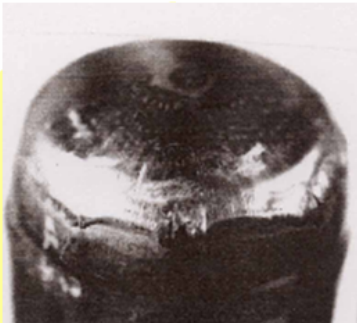

H13 (48HRC)

Wear

***Warm-forging punch
for CVJ parts***

Application (2)



H13 Wear

YXR33 Wear x 2



M2 Cracked

YXR33 Wear x 3



H10 Wear

YXR33 Heat checking x 2

Application (3)

Extrusion die

Wear & Heat checking

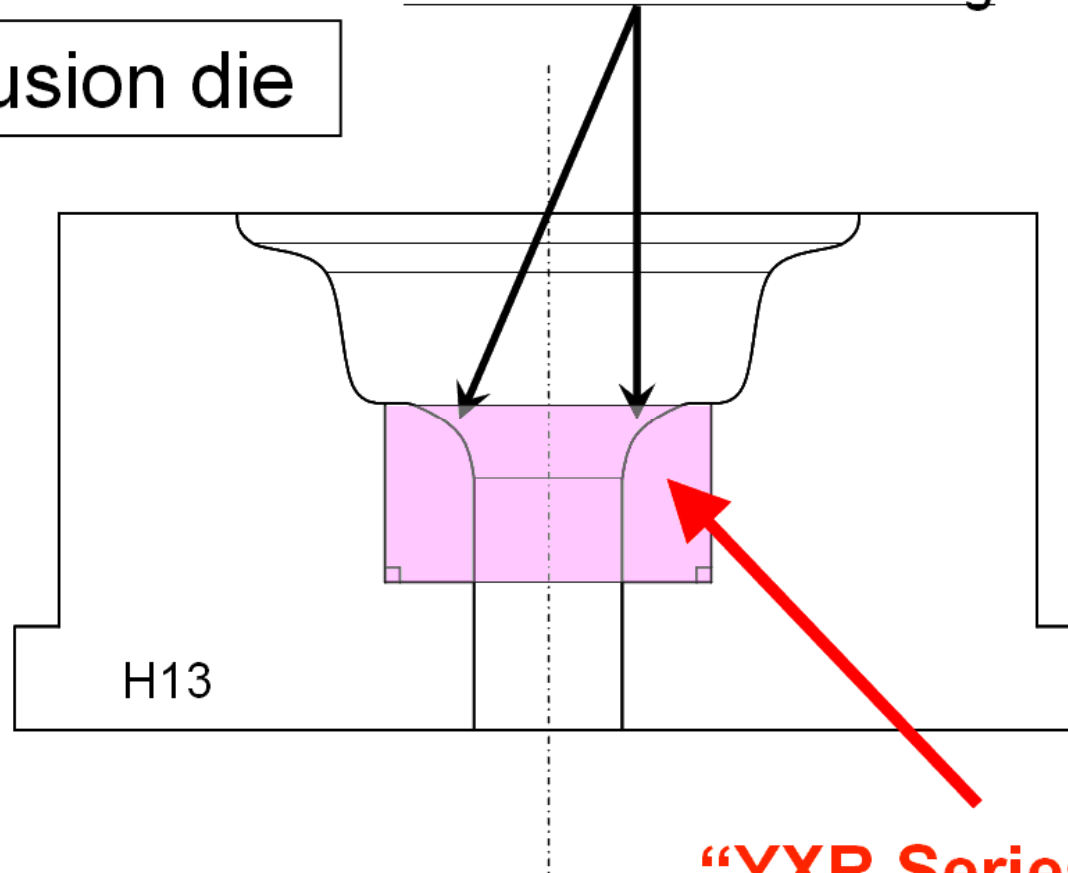

“YXR Series” Insert