

Our Dreams  
Onboard

## Steering & Brakes

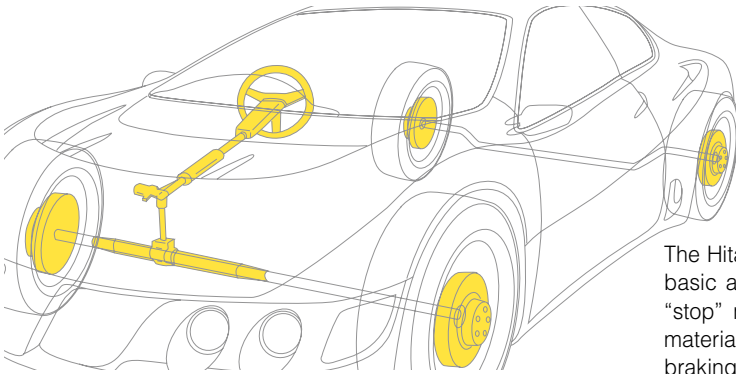

The Hitachi Metals Group supports the development of basic automotive functions, that is, “drive,” “turn” and “stop” motions, by supplying parts, components and materials for the electric power steering and antilock braking systems.

### Power Steering Components and Materials

#### **“NMX Series” Nd-Fe-B Sintered Magnets (Nd-Fe-B radial oriented Ring Magnets)** [NEOMAX Company]



Anisotropic ring magnets

Due to their ring shape, these NMX Series Nd-Fe-B Sintered Magnets with radial anisotropic ring magnetic field orientation can be easily assembled into rotors. In addition, the ring magnets allow skew magnetization, reducing cogging torque.

We also have segment-formed magnets that ensure high magnetic properties and design flexibility, allowing users to select optimum shapes and materials according to application.

These magnets are suitable for electric power steering motors, automatic shift gears and electric brake motors.

#### **“MICROLITE®” Normal Mode Choke Cores** [Information System Components Company]



MICROLITE® cores

The MICROLITE® Normal Mode Choke Cores use Fe-based amorphous materials of high saturation flux density and low core loss. They are available in three degrees of permeability: 100, 245 and 270. They can be used in environments that are exposed to considerable vibrations and/or temperature change as normal-mode choke coils in the EMC-compliant filters of various ECUs (Electric Control Units). In addition, they are suitable for manufacturing more compact coils with lower core loss.

## Transmission Components

### CVT Belt Material

[Specialty Steel Company]

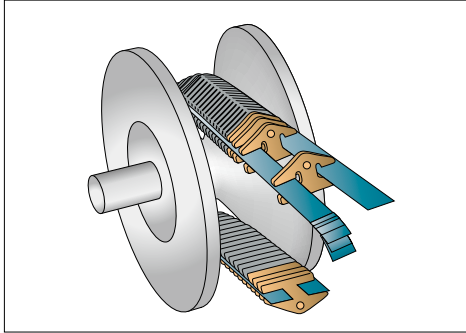

CVT belt material

The Continuous Variable Transmission (CVT) system transmits the motive power of an engine to a pulley using a belt, not through variable speed gearing. The globally renowned **YSS** Yasuki Hagane® steel is available as a material for such belts—the nucleus of the CVT system. With its accumulated alloy-design expertise and knowledge of metallic materials, as well as innovative evaluation techniques, the Group has succeeded in manufacturing a highly purified version of the Yasuki Hagane® steel that is ideal for CVT belts. This represents one of our efforts to improve the performance of transmissions—key components that concern the performance and safety of automobiles.

